

104-DIO-48S &  
104-DIO-24S

48 or 24 Lines of  
PC/104 DIGITAL I/O WITH COS

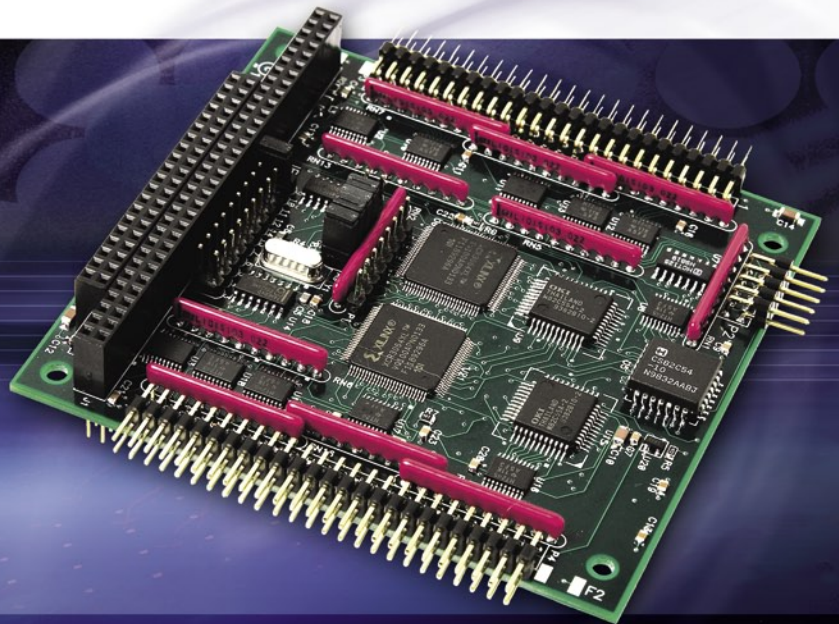
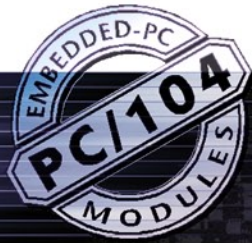

#### KEY FEATURES:

- 48 or 24 parallel lines of 82C55 digital I/O with tristate buffers prevent unintended control of external equipment
- IRQ on input change of state (COS) eliminates the need for constant polling
- High sink/source current 64mA/32mA
- I/O pulled up to 5V for contact monitoring
- Compatible with Opto-22 and other industry standard I/O racks

#### FACTORY OPTIONS:

- 82C54 with three 16-bit counter/timers for event counting, frequency output, pulse width and frequency measurement
- 0 to 70°C and -40 to +85°C versions available
- Economy version without COS feature
- Pull-down resistors on I/O lines
- Vertical I/O connector pins

The 104-DIO-48S and 104-DIO-24S provide a total of 48 or 24 lines of digital I/O with counter/timer for PC/104-based data acquisition. This low-cost, high-performance, reliable board features Change of State (COS) detection on user-selected ports, allowing the board to generate an interrupt port by port. Since one READ determines the data, there is no need for constant polling, which greatly reduces processor overhead and allows applications to run more smoothly.

The 104-DIO-48S board uses two 82C55A chips to provide a computer interface to the 48 I/O lines. Each chip provides two 8-bit ports and two 4-bit ports with software programmable direction. Each I/O line is buffered and capable of sourcing 32mA or sinking 64mA. Pull-ups to 5V are provided for contact monitoring. Optionally available is an 82C54 chip that includes three 16-bit counter/timers factory configured in an optimal module for use as event counters, frequency output, pulse width, and frequency measurement. Connections are made via two industry-standard 50-pin headers plus one ten-pin header for the optional counter/timer.

#### SOFTWARE

The 104-DIO-48S is supported for use in most operating systems and includes a free DOS, Linux and Windows 95/98/Me/NT/2000/XP/2003 compatible software package. This includes sample programs and source code in "C" and Pascal for DOS, and Visual Basic, Delphi, C++ Builder, and Visual C++ for Windows. Also included is a graphical setup program in Windows. Embedded OS support includes Windows XPe and CE. Linux support includes installation files and basic samples for programming from any user level via an open source kernel driver.



ACCES I/O Products, Inc. 10623 Roselle Street San Diego, CA 92121  
Tel: (858) 550-9559 (800) 326-1649 Fax: (858) 550-7322  
Email: [contactus@accessio.com](mailto:contactus@accessio.com) Website: [www.accessio.com](http://www.accessio.com)

## Block Diagram & Pin Configuration

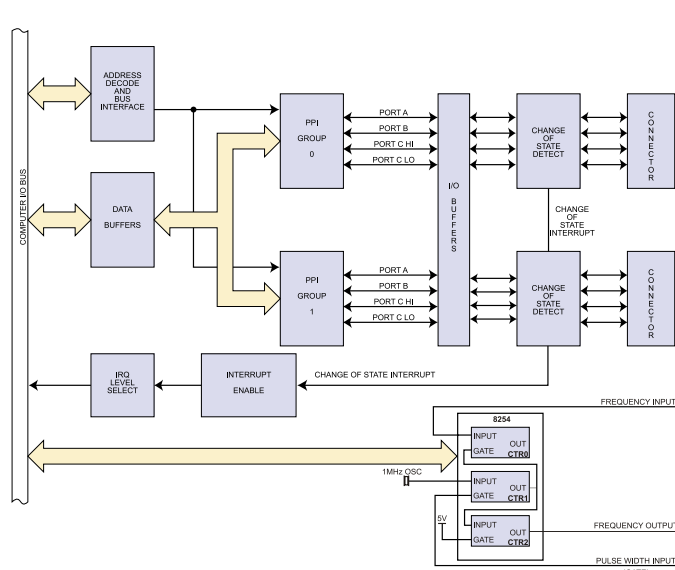

### I/O HEADER

Port C Hi	PC7	01	02	GND
Port C Hi	PC6	03	04	GND
Port C Hi	PC5	05	06	GND
Port C Hi	PC4	07	08	GND
Port C Lo	PC3	09	10	GND
Port C Lo	PC2	11	12	GND
Port C Lo	PC1	13	14	GND
Port C Lo	PC0	15	16	GND
Port B	PB7	17	18	GND
Port B	PB6	19	20	GND
Port B	PB5	21	22	GND
Port B	PB4	23	24	GND
Port B	PB3	25	26	GND
Port B	PB2	27	28	GND
Port B	PB1	29	30	GND
Port B	PB0	31	32	GND
Port A	PA7	33	34	GND
Port A	PA6	35	36	GND
Port A	PA5	37	38	GND
Port A	PA4	39	40	GND
Port A	PA3	41	42	GND
Port A	PA2	43	44	GND
Port A	PA1	45	46	GND
Port A	PA0	47	48	GND
+5 VDC		49	50	GND

### CTR/TIMER

Clock 0 Input	01	02	Gate 0 Input
Output 0	03	04	1MHz Clock (out)
Gate 1 Input	05	06	Output 1
Clock 2 Input	07	08	Gate 2 Input
Output 2	09	10	Ground

## Specifications

### Digital I/O

Chip	82C55A (each supports 24 lines)
Number of I/O lines	48 or 24 TTL/CMOS compatible
Direction	Programmable as inputs or outputs in two groups of 4 and 8 per 82C55A
Sink and source current	64mA and 32mA respectively
Pullup resistors	10K all input lines with optional pull-downs
Change of state detection (COS)	Port by port selectable on rising and falling edge
Throughput	Up to 1 Megabyte per second
Power output	Re-settable fused +5V at 500mA per 50-pin connector

### Interrupts

Number of interrupts	11
Interrupt requests	IRQ's 3-7, 9-12, 14, 15
Interrupt sources	Counter/timer outputs, external interrupt input, or DIO lines with change of state detection enabled by software

### Counter/Timers

Chip	Type 82C54
Counter/timers	3 x 16 bit
Maximum input frequency	10MHz
On-board time-base	1MHz
Signal type	TTL
Input voltage	Logic low: -0.5V min, 0.8V max; Logic high: 2.0V min, 5.0V max
Output voltage	Logic low: 0.0V min, 0.4V max; Logic high: 3.0V min, 5.0V max

### General

Power required	+5V at 50mA typical, all outputs open
Operating temperature	0 to 70°C, optional -40 to +85°C, all versions
Storage temperature	-50 to 120°C
Operating humidity	5% to 95% RH, non-condensing

## Ordering Guide

104-DIO-48S	48 lines of digital I/O with change of state detection
104-DIO-24S	24 lines of digital I/O with change-of-state detection